



Dajen MH Ltd

**APOLLO<sup>TM</sup>**

**Integrated  
Solar**

**Urban Lighting**

## THE TIMELESS STYLE FOR URBAN SPACE

With its stylish appearance and soft glow, Apollo all-in-one solar urban light creates an elegant and gentle air for all kinds of city activities, be it jogging, driving, shopping or socializing.

Apollo solar urban light is the ideal tool to create aesthetic consistency in cities composed of a mixture of heritage and modern architecture and who wish to highlight their historical patrimony while accentuating their commitment to the future.

As a versatile outdoor lighting solution, Apollo fits seamlessly into any urban setting with a range of installation options - single and double arm mounting.



Private sites



Building surrounds



Parks, promenades & pathways



Urban & residential streets



Car park



Dajen MH Ltd [sales@dajenmhltd.nz](mailto:sales@dajenmhltd.nz) | 021 627 425





## KEY FEATURES



Premium-grade Integrated All-in-one Design, Easy to Install and Maintain.



Environment Friendly & Electric Bill Free - 100% Powered by the Sun.



No Trenching or Cabling Work Needed.



Light On/off and Dimming Programmable Smart Lighting.



High Luminous Efficiency of 175lm/W to Maximize Battery Performance.



IP66 Luminaire Ensures Long Lasting and Consistent High Performance.



Five Years Warranty.



Dajen MH Ltd [sales@dajenmhltd.nz](mailto:sales@dajenmhltd.nz) | 021 627 425

## RELIABILITY UNEXPECTED VALUE



Only top quality mono - crystalline silicon solar panels with high efficiency and long lifetime are used.



Quality lithium batteries are used to store the energy, provide energy for immediate requirements, and enable a back-up for days when there is little or no sun.



High Lumen LED for maximum efficacy. Dedicated designed low-voltage solar controller technology with dimming capabilities for power-save management.  
Lifetime > 50,000 hrs and CRI nominal 70.



Microprocessor managed algorithms autonomously determine sunrise and sunset.



Easy to install without buying cables and rectifiers, directly on pole.

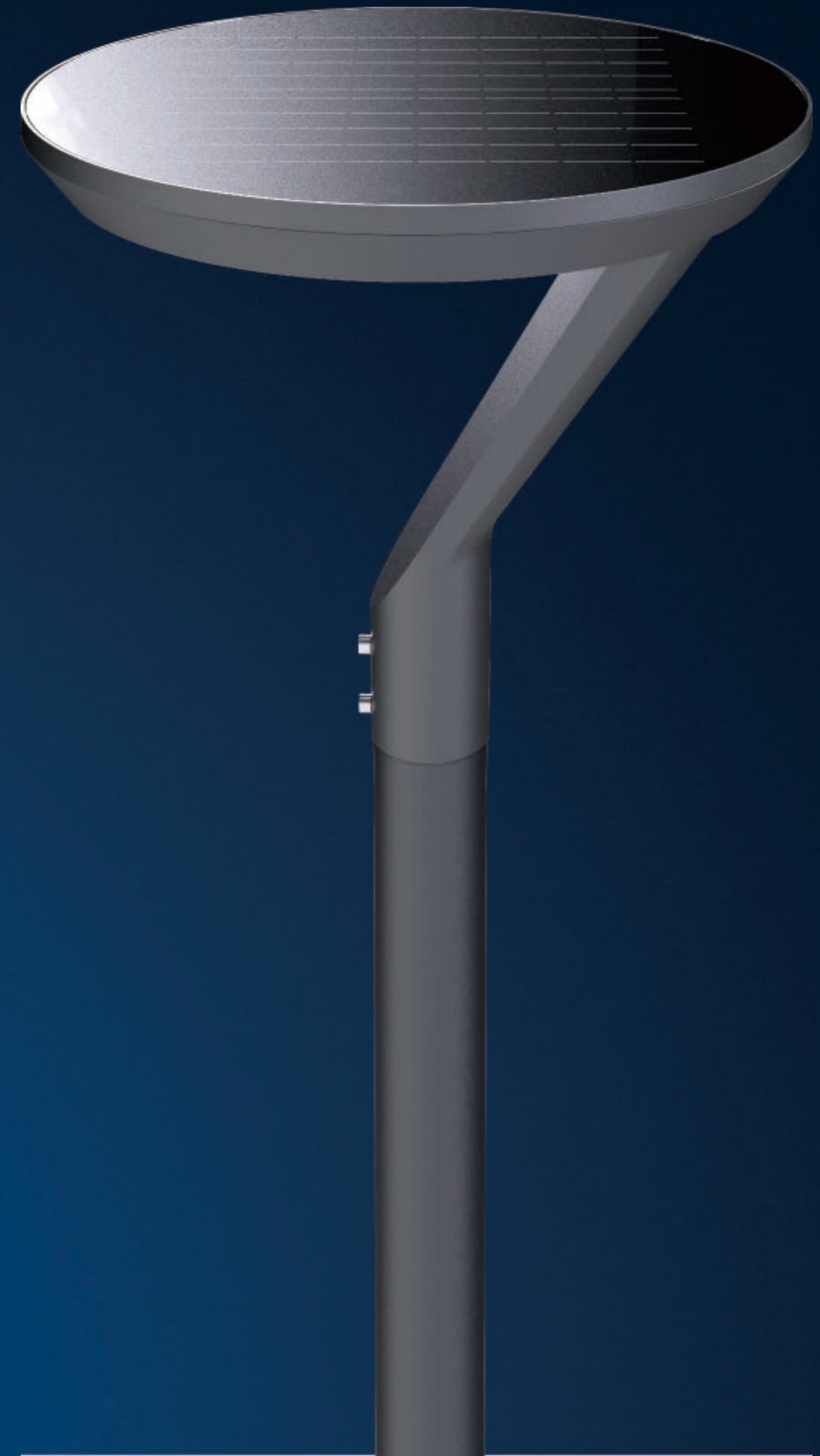

## PERFORMANCE



12W



175lm/W



Philips Lumileds 5050



Working mode: 100% brightness with motion, 30% brightness without motion.  
Working time: 14 hours.



≥70



4500~5500K(2500~5500K optional)



L70>150,000hours



65×150° / 90×150° / 100×150° / 150°



IP66



IK08



(Standard LiFePO4: Charge: 0°C to 60°C / 32°F to 140°F & Discharge: -20°C to 60°C / -4°F to 140°F)  
(Advanced LiFePO4: Charge: -20°C to 60°C / -4°F to 140°F & Discharge: -20°C to 60°C / -4°F to 140°F)  
Storing Temperature: -20°C to +60°C / -4°F to 140°F



## SPECIFICATIONS

| Part#      | Power | LED Efficacy | Solar Panel | Battery    | N.W    | Product Dimensions |
|------------|-------|--------------|-------------|------------|--------|--------------------|
| EL-UBAL-12 | 12W   | 175 lm/W     | 15W/18V     | 12.8V/12AH | 10.7kg | 482×482×467mm      |
|            |       |              |             |            | 10.0kg | 482×482×518.7mm    |
|            |       |              |             |            | 10.3kg | 482×482×568.7mm    |

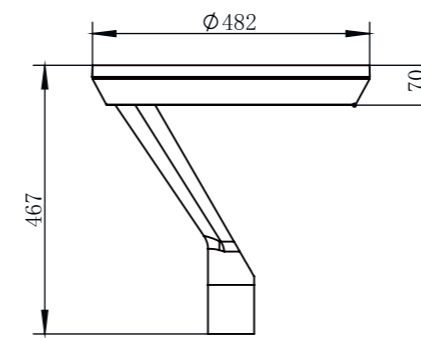

(Fit to D60mm pole)

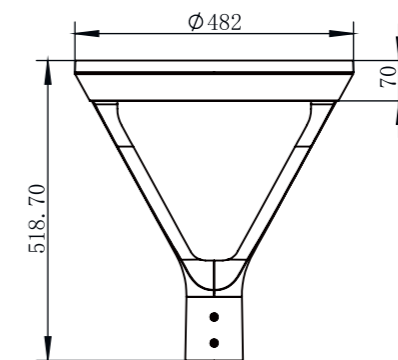

(Fit to D76mm pole)

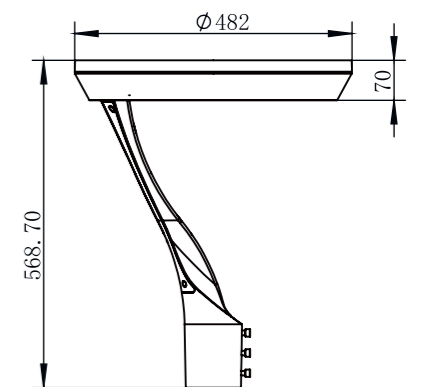

(Fit to D76mm pole)

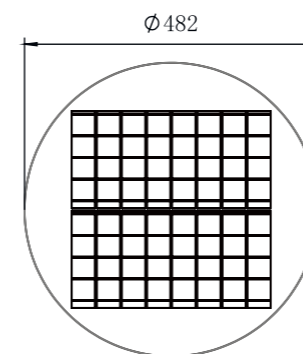

Dajen MH Ltd sales@dajenmhltd.nz | 021 627 425

# PHOTOMETRICS

65×150° (TYPE II-S)

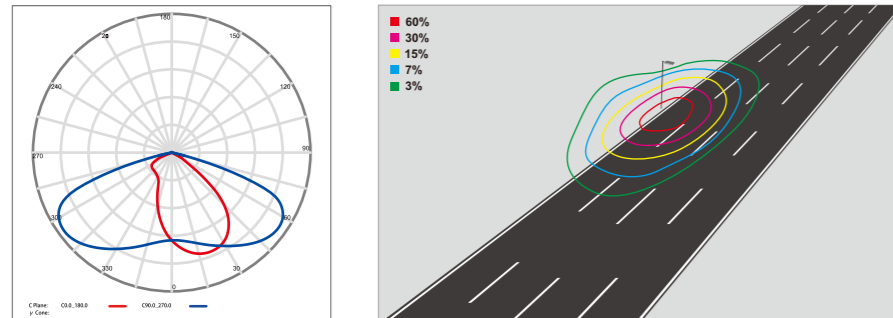

90×150° (TYPE III-S)

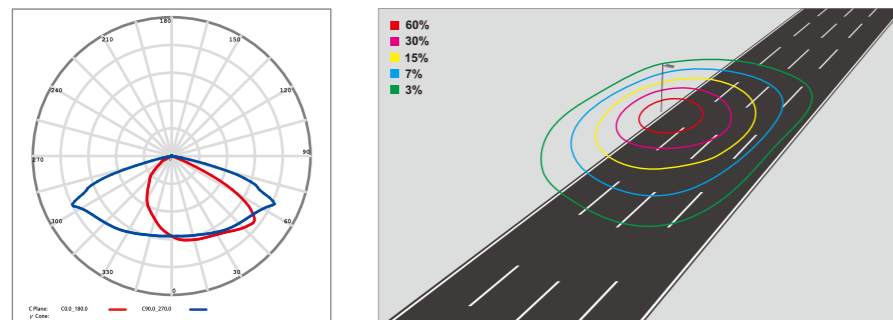

90×155° (TYPE II-S)

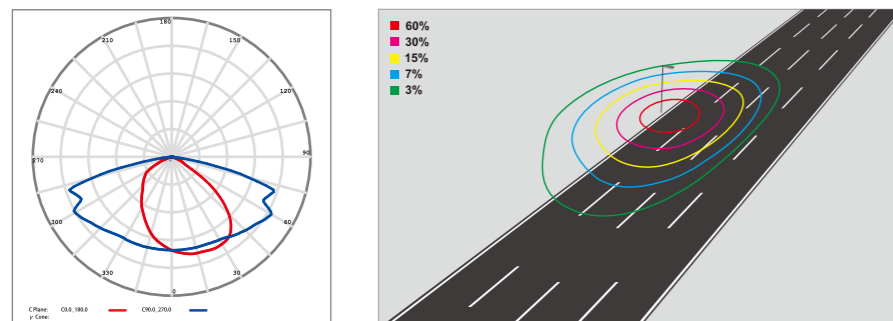

150° (TYPE V)

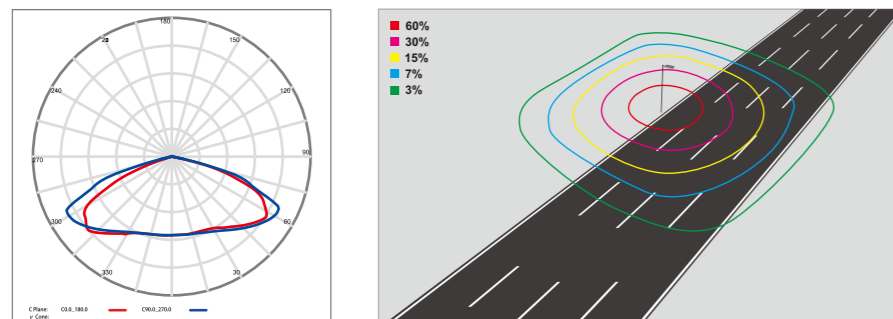

Default setting: 6m high Installation, 100% brightness.





## INSTALLATION NOTES

1. Due to variations in longitude and latitude at the installation site, the angle at which the sun's rays illuminate differs. During installation, it is crucial for the solar panel to be oriented towards the sun precisely at 12:00 noon. However, often due to factors like road direction and light poles, achieving this alignment becomes challenging. The solar panel must still maintain a horizontal position even if it can't be ideally oriented towards the sun at noon due to road lighting requirements.

Several conditions can lead to suboptimal functioning of standard lamps. Prior to making a purchase, it's important to communicate these factors to the salesperson and consider increasing the solar panel's power capacity:

- a. Any deviation below the horizontal plane of the solar panel, relative to the solar irradiation angle, will result in a significant decline in the solar panel's power generation efficiency.
- b. When installing solar lamps and lanterns, it's essential to avoid any obstacles that might block sunlight, such as trees or buildings.
- c. Natural elements like rain, ice, snow, dust, clouds, and bird droppings can reduce the solar panel's power generation efficiency.

Ensuring that the solar panel remains unobstructed by barriers like trees and buildings, and accounting for factors such as the solar panel's angle and external elements, are vital for optimal performance.

2. Install lamps at a considerable distance from areas prone to strong electromagnetic interference, such as high-voltage cables and high-power wireless transmission towers. These sources could potentially disrupt the lamp control system, leading to malfunctions and improper operation.

3. When the temperature drops below 0°C, the efficiency of lithium iron phosphate batteries for charge and discharge decreases. To prevent damage and the battery protection triggered by over-discharge, it's advisable to explain this to the sales

staff and consider increasing battery capacity before making a purchase.

4. Any environmental impact can result in a decline in the efficiency of solar panel power generation. Repeated discharge of the lithium iron phosphate battery might easily activate the protection mechanism, causing the lamps to stop functioning normally. Most lithium batteries can be restored to operation by disconnecting and reconnecting the battery-light source connection and the solar panel connection.

5. Once the battery protection has been deactivated and reactivated, our focus should be on identifying and resolving any natural environmental factors that compromise the efficiency of solar panel power generation, as well as minimizing the power consumption of the light source.

6. Install the lamps on days abundant with sunshine. The lamps are initially set to 30% power upon leaving the factory. Prior to installation and usage, ensure that the lamps can receive effective sunlight charging for at least 4 hours after activation. Failure to do so may trigger battery startup stress protection due to excessive discharge, leading to abnormal lamp operation.

7. The self-discharge and stress protection features of the lithium iron phosphate battery necessitate that if the lamp remains unused and uninstalled for a period of 60 to 90 days from the factory departure, it must undergo a 4-hour effective sun charging upon activation.

Instances where lamp functionality is compromised due to the aforementioned circumstances are not included in the warranty coverage. However, we are committed to assisting customers in identifying and analyzing the underlying causes, and devising plans for enhancements. It's important to note that lamps unable to activate after battery protection will not be covered by the warranty.



# ORDERING INFORMATION

